

# *A novel instructional design for the course of engineering drawing under the emerging network teaching*

Shengluo Yang<sup>a,\*</sup>, Shuoxin Yin<sup>b</sup>, Wenbo Zhu<sup>c</sup>

*School of Mechanical Engineering, University of Shanghai for Science and Technology, Shanghai, 200093, China*

*<sup>a</sup>yangshengluo@usst.edu.cn, <sup>b</sup>233381504@st.usst.edu.cn, <sup>c</sup>teacherzwb@163.com*

*\*Corresponding author*

**Keywords:** Instructional design, Engineering Drawing, Network Teaching, Ideological and Political Elements

**Abstract:** Moral cultivation is an important goal of higher education, and the curriculum of ideological and political education is an important way to carry out ideological and political education. The course of engineering drawing, which has a wide audience, is a professional basic course of engineering and is the precursor to educating students. Affected by COVID-19, college teaching has been switched to online teaching. How to carry out high-quality professional courses and ideological and political education in online teaching is an important problem faced by college teachers. This paper is based on the network teaching platform. It constructs rich teaching resources to realize diversified and efficient teaching. It deeply excavates the new elements of ideological and political education in the epidemic situation. These elements are integrated into the teaching process to realize the collaborative education of knowledge and ideological education. Furthermore, it extracts new cases of ideological and political education outside the classroom. This is in combination with major social needs to guide students to establish lofty aspirations. The goals here include solving major national needs, and realizing all-round ideological and political education throughout the entire process. Finally, the work can improve the teaching quality of professional courses, improve students' ideological and political quality, and achieve the trinity of knowledge transfer, ability training, and value guidance.

## 1. Introduction

Fostering virtue through education is an important goal of higher education. This requires university teachers to organically combine knowledge transmission with ideological and political education in their daily education and teaching process. This innovative teaching method enables ideological and political education to run through the entire teaching process, forming a synergistic effect between professional knowledge education and ideological and political education[1,2]. Therefore, curriculum ideology and politics are of great significance in college education and teaching.

Engineering Drawing is a fundamental course for engineering majors. It has a wide audience and started early, while also providing guidance for ideological and political education in higher education.

However, Engineering Drawing has the characteristics of abstract content, numerous theories and standards, multiple key and difficult points, and detailed knowledge points, making it difficult for students to understand clearly<sup>[2]</sup>. At present, the length of the engineering drawing course has been reduced to a certain extent. This phenomenon brings great challenges to teachers and students. Therefore, while ensuring normal high-level teaching, it is an important issue worth exploring how university teachers can effectively carry out ideological and political education.

In recent years, the COVID-19 epidemic has disrupted normal teaching work and posed new challenges to education. During the COVID-19 epidemic, many universities closed their campuses, which made students spend most of their time studying in dormitories or at home. In this teaching mode, it is difficult for teachers to control the learning state of students in the classroom, resulting in unsatisfactory interactive effects in the classroom. At this time, both professional knowledge education and ideological and political education are facing great challenges<sup>[3,4]</sup>. Therefore, it is an important problem for university teachers to carry out diversified teaching and ideological and political education based on network platforms during the normal situation of the epidemic.

This paper, taking technical drawing as an example, explores a variety of effective teaching methods based on web-based teaching platforms, and explores new elements of ideological and political concept teaching in the context of the epidemic. This makes the education and teaching goals of knowledge imparting, ability training, and value guiding come true<sup>[2,5]</sup>.

## **2. Teaching Design Method Based on Network teaching**

### **2.1 Construction of Diversified Teaching Resources**

Establishing teaching resources is the basis of network teaching<sup>[6]</sup>, which directly affects the teaching quality and students' learning effect. In this novel instructional design, we combine abundant and excellent teaching resources, and according to the Super Star Learning Platform, we set up a network of teaching resources for the engineering drawing course. It consists of the following four parts:

#### **(1) Basic materials for course learning**

The basic materials of the course are selected, combined, and summarized before being uploaded to the learning platform. Specific resources include electronic courseware, learning tasks, lists of knowledge points, two-dimensional and three-dimensional part drawings, and the homework library.

#### **(2) Resources for self-directed learning**

It includes independent learning resources outside the classroom. These stand-alone resources are numerous, such as micro-lesson explanations of knowledge points, video display animation, high-quality online classes, and other resources.

#### **(3) A platform for teachers and students to interact**

Based on the Super Star Learning Platform, we can not only publish the homework information on the platform and answer the students' questions online but also know the students' status and adjust the teaching schedule in time.

#### **(4) Practical model library and excellent works library**

Upload 3D model drawings and 2D engineering drawings related to knowledge points, physical drawings, and 2D drawings of machined parts, as well as excellent work in students' homework. This can form a practical model library and an excellent works library, which helps students understand the knowledge points and stimulates their learning enthusiasm.

### **2.2 Teaching Process Design Based on Diversified Learning Resources**

Before the class, the release of this class learning tasks and teaching aids video so that students

preview ahead of time. The goal is to help students preview more effectively but also to promote their interest in learning so that, in the end, they can achieve a good preview effect.

During teaching, courseware and video playback are used to attract students' attention and help them follow the lecture's progress. At the same time, online group discussion will be introduced, allowing students to make their own courseware or related video points of knowledge for a heated discussion.

The homework is uploaded through the learning platform. After it has been corrected, students can view the explanation on the internet to understand its shortcomings.

### 2.3 Knowledge Application and Practice Extension

In order to promote students' interest in learning and increase the practicability of learning, a knowledge application extension module will be introduced. By studying practical cases and videos related to the course, students can achieve a comprehensive and profound grasp of knowledge. For example, the knowledge application development module contains actual photos of the parts covered by the course, explanations of application scenarios, and videos of actual work.

## 3. Construction of Teaching Ideological and Political Material Database

University teachers should explore new elements of ideological and political courses in epidemic prevention and control in light of the current epidemic prevention and control background. For example, when teaching the drawing of pump parts, combined with the great demand for breathing valves under the current epidemic stress, the ability to quickly and accurately draw is emphasized to meet the urgent needs of countries and enterprises.

### 3.1 The Drawing of Pump Body Parts

The parts of the pump body are widely used in actual production and life. It is of great practical significance to quickly read and accurately draw them. The pump body parts have a complex structure and a large number of views, which make them challenging for students to master. Figures 1 and 2 show the three-dimensional drawings and engineering drawings of pump body parts, respectively.

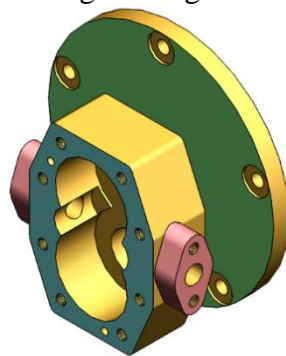

Figure 1: The three-dimensional model of the pump body.

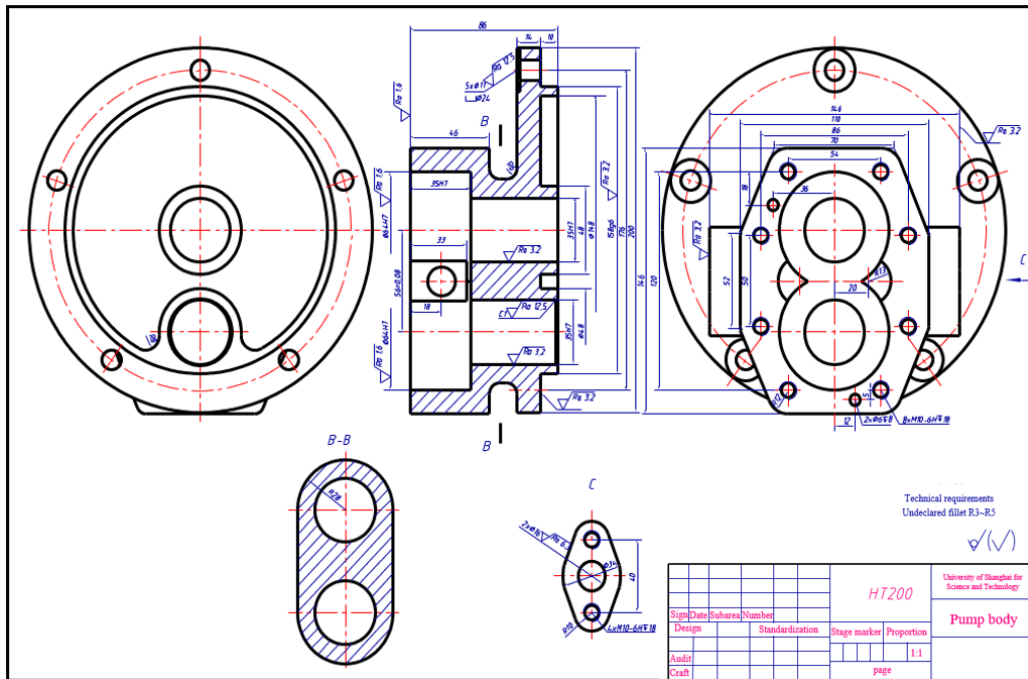

Figure 2: The engineering drawing of the pump body.

### 3.2 Combine Case with Ideological and Political Elements

During the COVID-19 pandemic, breathing valves related to pumps are urgently needed by patients. Based on this situation, while teaching pump body parts, the rapid design and drawing of breathing valves during the emergency were the ideological and political cut-in points to teach. Teachers should guide students to master professional skills, dare to assume social responsibilities, and flexibly apply knowledge to actual production and life needs. In the urgent needs of the country and society, we can quickly and accurately produce product design, effective production of engineering drawings, and short-term delivery to contribute to society.

### 3.3 Establish Diversified Network Teaching Resources Related to Curriculum Ideology and Politics

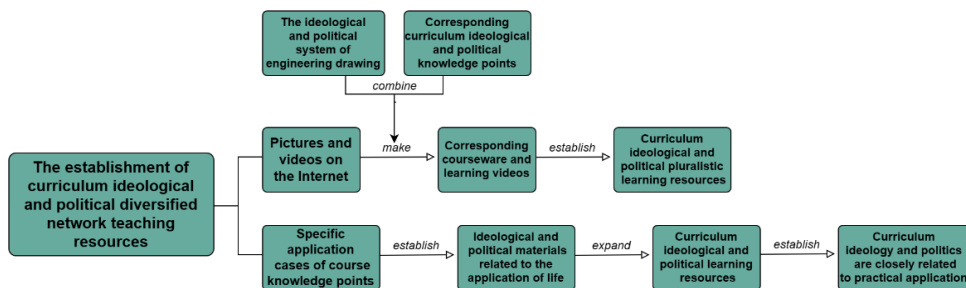

Figure 3: The flow chart of the establishment of diversified network teaching resources of curriculum ideology and politics.

We can use the rich picture and video resources on the Internet to combine them with the ideological and political knowledge system of engineering drawing. After that, we can make courseware and learning videos for the corresponding knowledge points of ideological and political

courses. Finally, a variety of ideological and political course learning resources will be established. At the same time, it can also be combined with specific cases of curriculum knowledge points for the production of life knowledge points of the application of the establishment of the corresponding ideological and political teaching materials. After that, college teachers can expand the learning resources of curriculum ideology and politics, and make the curriculum ideology and politics closely related to practical application. The specific process is shown in Figure 3.

### **3.4 An Interactive Mechanism Combining Online and Offline Communication**

In the ideological and political education of offline classrooms, the collection of ideological and political materials and the display of works are carried out in the way of group discussion and comment. In this way, we can mobilize students' enthusiasm and participation in ideological and political education, and deepen students' understanding of ideological and political education.

Outside the classroom, based on the Super Star Learning Platform, published course ideological and political discussion. After that, we will track the students' learning progress and speaking, integrate the offline work display and online discussion into the usual performance evaluation mechanism, and construct the online interaction mechanism.

## **4. Case Study**

### **4.1 The Whole Process Ideological and Political Education Practice Method**

The three-whole education requires the whole staff, the whole process, and the all-round education. In order to achieve a good effect of ideological and political education, ideological and political education outside the classroom is also particularly important. This requires teachers to pay close attention to current affairs, combine national affairs and people's livelihood issues, extract ideological and political elements, and finally form ideological and political education materials. We should run ideological and political education through the whole process of education and teaching and the whole process of students' study. Whether inside or outside the classroom, online or offline, or inside and outside the school, ideological and political ideas should be fully covered. In this way, the students will have a gentle and silent education.

### **4.2 Rapid Construction of Mask Production Line**

Under the epidemic situation, manufacturing enterprises can meet people's large demand for masks by rapidly building mask production lines. From this matter, the ideological and political elements guided by the needs of the people are extracted and then used to cultivate the students' sense of home and country, responsibility, dedication, and exquisite technology.

Taking the rapid construction of the mask production line shown in the picture as an example, we should educate students to be driven by social needs, face the major needs of the country, design people-oriented, meet the urgent needs of society, and promote education for social development.

## **5. Conclusion**

In view of the extensive teaching of engineering drawing and the characteristics of network teaching in the current epidemic situation, this paper studies the ideological and political problems of network teaching in the epidemic situation.

The study is divided into three steps. The first step is to build a rich teaching material base based on the Super Star Learning Network platform, which can be used to achieve diversified and efficient

teaching. The second step is to combine the current epidemic prevention work, excavate the new elements of curriculum ideological and political education in the context of the epidemic situation, and integrate them into curriculum education to achieve the organic coordination of education. The last step is to extract new ideological and political thought from the actual social production, which can be used to expand the ideological and political work outside the classroom and form an all-around ideological and political education model in the whole process.

Finally, the teaching effect of professional courses should be improved, and students should be guided to form a correct outlook on life and values so as to form the educational goal of cultivating people with virtue.

## Acknowledgements

This work was supported by the Training and Funding Program for Young Teacher in University of Shanghai (Grant No. ZZ202303033); 2023 Undergraduate Teaching Research and Reform Project of University of Shanghai for Science and Technology (Office of Academic Affairs, University of Shanghai for Science and Technology [2023]5); 2023 Construction Project of Undergraduate Demonstration Course with Ideological and Political Content (Office of Academic Affairs, University of Shanghai for Science and Technology [2023]18).

## References

- [1] Luan Yingyan, Wang Ying, He Rui. (2020) *Course Reform of Engineering Graphics Against the Background of Emerging Engineering Education*. *Journal of Graphics*, 41,164-168.
- [2] Zhang Wenfang, Hu Qingchun. (2021) *Teaching Reform of Engineering Drawing Course Against the Background of Emerging Engineering Education*. *Advances in Educational Technology and Psychology*, 5, 8-12.
- [3] Chen Huangfei, Fang Zhuangying. (2019) *Teaching Reform and Practice of Engineering Drawing and Electrical CAD*. *Advances in Social Science, Education and Humanities Research*, 314, 589-593.
- [4] Huang Min, Wang Shuaihui, Wang Jingyang. (2022) *Exploration and Practice of Curriculum Ideology and Politics Education in Engineering Majors*. *Proceedings of the 6th International Seminar on Education, Management and Social Sciences*, 687, 1605-1611.
- [5] Wei Xia. (2023) *Research on the Ideological and Political Elements of Science and Engineering Curriculum Mining*. *China Modern Educational Equipment*, 5, 102-103.
- [6] Kentel, Aysu Sagun. (2022) *Emergency Remote Teaching of Technical Drawing during the COVID-19 Pandemic*. *Int J Mob Blended Learn*, 14, 1-18.